

GAO

Report to the Chairman, Subcommittee  
on Energy, Committee on Science,  
Space, and Technology, House of  
Representatives

July 1993

# FOSSIL FUELS

## The Department of Energy's Magnetohydrodynamics Development Program



---

---

**Resources, Community, and  
Economic Development Division**

B-253570

July 29, 1993

The Honorable Marilyn Lloyd  
Chairman, Subcommittee on Energy  
Committee on Science, Space, and Technology  
House of Representatives

Dear Madam Chairman:

The Department of Energy (DOE), along with industry, has been involved for many years in developing magnetohydrodynamics (MHD) technology for generating electrical power. MHD is a potentially high-efficiency technology that generates electrical power from coal by passing extremely hot coal combustion gases through a channel surrounded by a magnetic field. In recent years, DOE's MHD program has focused on demonstrating the proof-of-concept, or feasibility, of coal-fired MHD electric power plants.

In response to your request and subsequent discussions with your office, this report addresses your concerns about DOE's progress in completing its MHD proof-of-concept (POC) program. Specifically, it addresses (1) the financial history of developing MHD technology, (2) progress in meeting the POC program's schedule, (3) potential problem areas and concerns, (4) DOE's management of the POC program, and (5) DOE's future plans for MHD.

---

**Results in Brief**

By September 1993, the federal government will have spent about \$800 million for research and development of coal-fired MHD power generation technology. These expenditures, which began in the 1960s, include DOE's funding for the POC program. DOE began implementing the POC program in September 1987 and had initially expected to complete the program by September 1992 at a federal cost of \$172 million (in 1988 dollars). However, the program was extended for 1 year because of funding shortfalls, which resulted in delays in the development and procurement of some of the required hardware and in increased costs. By September 30, 1993, DOE will have spent about \$223 million in appropriated funds under the POC program. This is equivalent to about \$203 million in 1988 dollars.

---

The overall objective of the POC program was to provide the data base needed for the private sector to decide whether to pursue developing and using MHD technology at new or existing commercial power plants. DOE expects to meet this objective by September 1993 but will fall a total of about 1,000 hours short of the test time that had been planned for DOE's two testing facilities. As a result, DOE believes the test data may not be as statistically reliable as the data otherwise could have been if all the planned test hours were completed.

Although DOE believes that the tests to date have shown the technical feasibility of each of the major subsystems in the MHD process, questions have arisen about costs, problems have occurred in the early test runs that have not yet been resolved, and unknowns and uncertainties must be faced related to fully integrating and scaling up all the components of an MHD system. Also, other advanced technologies will need to be developed and used with the basic MHD technology if this type of power generation system is to ultimately reach the high-efficiency potential expected.

In managing the POC program, DOE has focused on the major technical issues and has maintained an open process for obtaining input from the scientific community. Information on the activities and progress of the program has been widely disseminated.

The private sector submitted a proposal for federal cost-sharing for an MHD demonstration project under DOE's Clean Coal Technology program, but it was not selected because some other project proposals were considered better prospects. DOE has requested \$4.8 million to begin the shutdown of the POC program. The total shutdown costs could range from \$8 million to \$16 million, depending on the extent of site and environmental restoration costs and related contingencies at DOE's testing facilities.

---

## Background

The basic MHD process starts with a combustor where coal is burned at very high temperatures. Exhaust gases from the combustor are funneled through a channel containing electrodes and surrounded by a magnet that creates a magnetic field. The interaction of the gases and the magnetic field generates electric current that is extracted through the electrodes. Potassium salt is added in the combustor and used as a "seed" to enhance the electrical conductivity of the combustion gases. To boost electrical output, high-temperature exhaust heat from these gases can be recovered and used to generate steam, which powers a conventional steam turbine generator. The combustor and channel and related equipment are referred

---

to as the MHD "topping cycle." The steam turbine generator and related equipment are referred to as the "bottoming cycle." Appendix I shows a typical MHD configuration.

Much of the MHD effort in the 1960s and 1970s was focused on developing and testing individual MHD components at several small, laboratory-size test facilities. In the early 1980s, DOE began developing and testing MHD components at two larger-than-laboratory test facilities that were constructed in the late 1970s. These facilities are owned by DOE and operated by private contractors. The Component Development and Integration Facility is located in Butte, Montana, and the Coal-Fired Flow Facility is located in Tullahoma, Tennessee—hereinafter referred to as the Montana facility and the Tennessee facility.

In 1984, DOE held public meetings to discuss the direction of MHD research and to formulate a more focused approach to its MHD program. The MHD POC program was established as a result of a consensus among government and industry representatives participating in these meetings. DOE formulated its detailed plans and objectives for the POC program during the next 3 years and awarded the first contracts under the POC program in September 1987. The POC program has been managed by DOE's Pittsburgh Energy Technology Center (PETC).

The POC program's primary objectives are to test and demonstrate the proof-of-concept of (1) the topping cycle system; (2) the bottoming cycle system; and (3) the potassium seed regeneration system, which is intended to economically convert the spent potassium seed recovered from the bottoming cycle to a sulfur-free potassium compound that can be reused in the combustor. In addition, the POC program was to study the feasibility of retrofitting MHD power systems to existing coal-fired plants. The topping cycle is being tested at the Montana facility, the bottoming cycle at the Tennessee facility, and the seed regeneration system at a TRW plant in California. The retrofit studies were done on a commercial power plant in Florida and a commercial power plant in Montana.

## Funding History of Research and Development of MHD Technology

### Federal Funding

By the end of September 1993, about \$800 million will have been spent by the federal government for research and development of coal-fired MHD power generation technology, dating back to the 1960s. Of this amount, \$223 million will have been spent for the MHD POC program, which began implementation in September 1987 and is scheduled to be completed by September 30, 1993.

According to DOE, the federal government spent about \$4 million on MHD research during the 1960s. The remainder of the \$800 million in federal funds has been provided on an annual basis since the 1970s. Figure 1 shows the level of federal funding since 1973.

Figure 1: MHD Federal Funding Trend

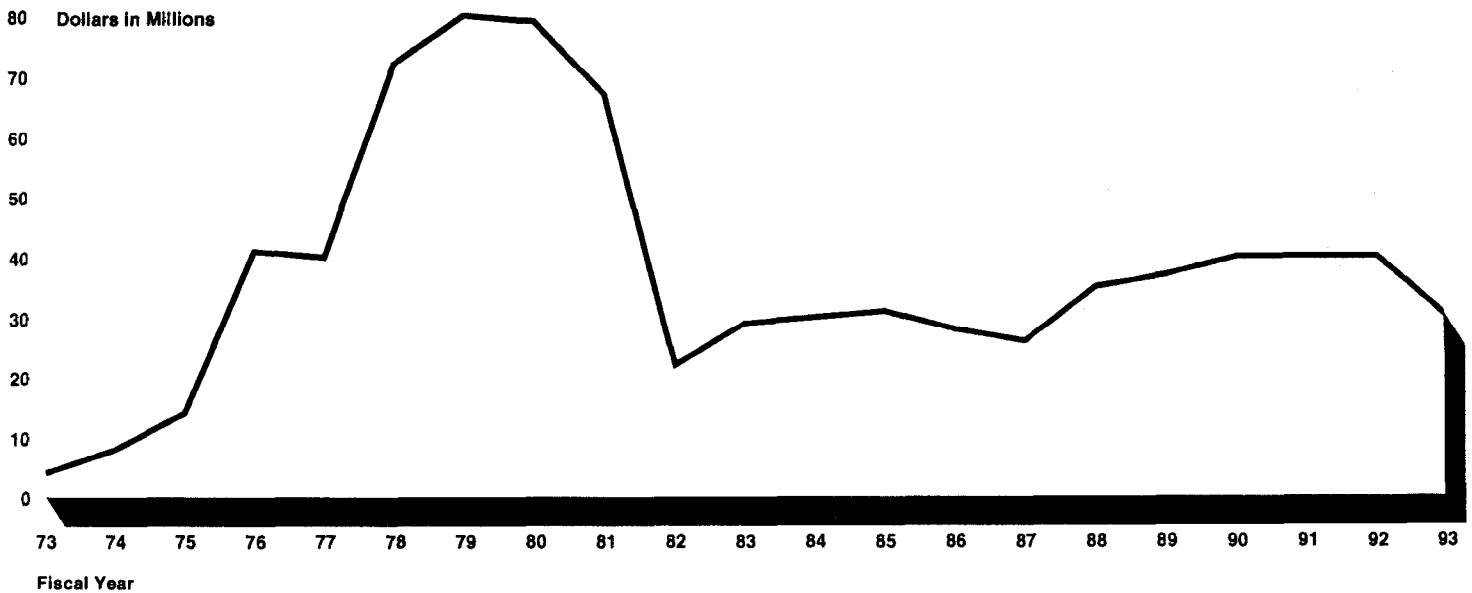

---

## Private Sector Contributions

According to DOE's MHD program manager at PETC, the private sector contributed about \$50 million to share the costs of federally funded MHD research and development before fiscal year 1986. The official said that this cost-sharing was done informally and was primarily in the form of in-kind contributions.<sup>1</sup> Not much documentation was available on the specific contributions.

Beginning in fiscal year 1986, annual appropriations acts have required the private sector participating in DOE's MHD program to share a portion of the program's costs under specific cost-sharing formulas. In determining the portion of the program's costs to use as a basis for cost-sharing, the law allows certain costs to be excluded from the calculation. For example, the private sector is not required to share the costs of constructing or operating government-owned facilities or the costs of government organizations, national laboratories, or universities involved in MHD research and development work. After these costs are excluded, the private sector is required to match a percentage of the remaining MHD program costs by providing cash and/or in-kind contributions. The cost-share match was set at 10 percent for fiscal year 1986 and 20 percent for the following year. It was gradually increased over the next 3 years (1988-90) to 35 percent and has remained at that level through fiscal year 1993.

Under the law, the specified percentage for private sector cost-sharing does not have to be met on each contract but must be met in total for each fiscal year. According to DOE, the private sector was required to contribute a total of \$8.1 million during fiscal years 1986 through 1991 but actually contributed \$10.3 million, primarily in the form of in-kind contributions.<sup>2</sup> (App. II provides a comparison of the required and actual private sector contributions for each year of this 6-year period. It also provides a summary of the private sector's contributions by industry participants.) TRW and the Electric Power Research Institute (EPRI) were the largest contributors. TRW contributed equipment, management support, and forgone fees valued at \$7.7 million. EPRI contributed equipment valued at \$1.6 million.

---

<sup>1</sup>In-kind contributions represent the value of donated equipment, materials, services, facilities, etc., that are provided by the private sector.

<sup>2</sup>Information on industry's actual contribution for fiscal year 1992 and projected contribution for fiscal year 1993 was not available as of June 1993.

---

## Progress of the POC Program in Meeting Its Schedule

DOE originally planned to complete the POC program by September 1992 but extended it through September 1993 because of lower funding levels than originally planned, which resulted in delays in the development and procurement of hardware. According to DOE officials, the primary goals of the POC program will be met by September 1993, even though DOE does not expect to complete all of the testing that was originally planned.

DOE's overall objective for the POC program was to develop the technology base needed for the private sector to decide whether to pursue developing and using MHD technology at new or existing commercial power plants. The activities at the Montana and Tennessee test facilities were intended to provide the technical and environmental data needed by industry to design and construct a commercial-scale, fully integrated MHD topping cycle and bottoming cycle. The seed regeneration component's objective was to demonstrate the technical and economic feasibility of recovering the used potassium seed and converting it for reuse in the MHD process. The retrofit studies were included in the POC program to provide a conceptual design for a site-specific, coal-fired MHD retrofit plant.

In planning the implementation of the POC program, DOE estimated that the program would take 5 years to achieve these objectives and cost \$172 million (in 1988 dollars). DOE began implementing the program in September 1987 and estimated that it would be completed by September 30, 1992. However, funding for the first 3 years of the program was lower than planned and insufficient for the development and procurement of the hardware needed for the MHD projects. According to DOE, the resulting delays in procuring and testing the hardware increased the costs of the program to about \$223 million (about \$203 million in 1988 dollars) and caused it to be extended through September 1993.

DOE's POC program plan provided for the development and installation of the MHD topping cycle components at the Montana facility, followed by 1,000 hours of duration testing to develop technical and environmental data on the integrated topping cycle system's performance. The prototypical hardware for the topping cycle system was installed at the Montana facility in June 1992, and duration testing of the hardware and system began in October 1992. DOE planned to continue the testing off and on through September 1993 to accumulate technical and environmental data needed on the system's operating performance. According to DOE officials, the topping cycle successfully generated 1-1/2 megawatts of electrical power, as expected, but some problems were encountered in the early test period; these are discussed in the next section.



DOE's MHD program manager at PETC told us in May 1993 that only about 600 hours of duration testing are expected to be completed on the topping cycle by September 1993 because it took longer than anticipated to put the system back into operation after it was shut down for inspection. The MHD channel in the topping cycle system was designed to operate for 2,000 hours. According to the official, DOE planned 1,000 hours of duration testing to accumulate data that could be extrapolated and projected to determine the ability of the MHD channel to operate for 2,000 hours. The official said that DOE and contractor personnel will still be able to use the data obtained in 600 hours of testing to make such judgments, but the data may not be as statistically reliable as 1,000 hours of test data. DOE officials also told us that 200 of the originally planned test hours were to involve high-sulfur coal, but this part of the test will not occur because of the lower number of test hours now planned.

According to a DOE-commissioned November 1990 assessment of the POC program by an independent panel of private sector experts, the most important POC testing goal is to demonstrate the durability of the topping cycle components. The assessment questioned whether even the planned 1,000 hours of testing would be adequate to allow for sufficient data to be collected and analyzed to demonstrate the durability of the MHD generator and other critical components of the topping cycle system. The assessment emphasized that the allotted time for duration testing should be increased to increase the probability of success and pointed out that utilities need such data on which to base a decision on pursuing MHD as a future technology to commercialize.

To develop technical and environmental data for the bottoming cycle subsystem, DOE planned 4,000 hours of long-term testing at the Tennessee facility—2,000 hours burning high-sulfur Illinois coal and 2,000 hours burning low-sulfur Montana Rosebud coal. This facility has completed the 2,000 hours of testing Illinois coal but, because of a shortage of funds, is currently scheduled to complete only 1,400 hours of testing Montana coal by September 1993. Therefore, the Tennessee facility will fall about 600 hours short of its originally planned tests. DOE officials told us in June 1993 that data obtained from 1,400 test hours may not provide as good a statistical basis for projections as data obtained from 2,000 test hours and may result in overdesign of future MHD equipment, if such equipment is built, because of uncertainties. According to officials of the University of Tennessee Space Institute, which operates the Tennessee facility for DOE, the tests that have been conducted have provided extensive data on heat transfer characteristics of materials to be used in an MHD bottoming cycle

---

facility. They said the tests have also provided useful data on the mechanisms for removing ash deposits and on effective means to control particulate emissions.

The seed regeneration system component of the POC program was aimed at developing a process that would economically recover and regenerate potassium seed used in the combustion of high-sulfur coals in MHD systems. TRW has completed the design and construction of a seed recovery and regeneration system at its plant in California. During 1991 and 1992, TRW used this system to process 17.5 tons of spent seed that had been collected by the Tennessee facility during bottoming cycle testing of Illinois high-sulfur coal. About 12 tons of regenerated seed has been shipped to the Montana facility for use in some topping cycle test runs this summer. TRW is also evaluating the recovery and regeneration of spent seed from Montana Rosebud low-sulfur coal, which is processed differently. This testing is being done at laboratory scale and is expected to be completed in August 1993. TRW also plans to develop engineering designs for two types of seed regeneration plants by September 1993, one that can process spent seed from high-sulfur coal and one that can process spent seed from low-sulfur coal. According to DOE officials, the TRW seed regeneration system performed adequately for a first-of-its-kind system, but they also said that further development of the system would improve its cost-effectiveness, an issue discussed in the next section.

The purpose of the retrofit studies component of the POC program was to develop conceptual designs for two potential MHD retrofit power plants. These conceptual designs were to be used to evaluate the practicality of adding an MHD system to an existing power plant and to determine the key technical cost, schedule, and performance considerations for designing and developing an MHD retrofit plant. DOE awarded contracts for these studies in late 1987. The studies were completed in September 1989 using power plants in Florida and Montana as a basis for determining what a retrofit would look like on an existing plant. According to officials at the University of Tennessee Space Institute, the results of these studies have helped to better define the facility design changes and conditions that needed to be simulated in the bottoming cycle tests at the Tennessee facility. DOE had planned to update the studies with data obtained from testing the components of the POC program, but funds were not made available for this purpose.

---

## Potential Problem Areas and Concerns

A number of problems or uncertainties are associated with MHD technology involving slag removal in the combustion chamber, durability of the channel, cost-effectiveness of the seed regeneration process, performance of fully integrated components, and potential scale-up problems as increasingly larger MHD systems are built. Also, some new, advanced technologies are needed if MHD efficiencies are to exceed those of competing coal technologies that are further developed than MHD.

---

## Slag Removal Problems

After the topping cycle system had been in operation generating power for about 75 hours, the system was shut down for inspection. The inspection disclosed problems in the combustor's performance. The system that is used in the combustor to capture most of the slag, which is formed when coal is burned, did not perform as well as the Montana facility's contractor personnel had expected.

The combustor is designed so that a large portion of the slag is ejected at the bottom of the combustor, rather than going through the MHD channel attached to the combustor. Contractor personnel anticipated that the system would capture about 70 percent of the slag, but it captured about 50 percent. According to POC program officials, the slag that leaves the combustor and goes through the MHD channel absorbs part of the potassium seed used to increase the conductivity of the combustion gases. This absorption requires more seed to maintain the electrical power output and reduces the amount of seed that can be economically recovered by the seed regeneration system. At the time of our review, PETC and contractor personnel were exploring ways to overcome this problem, but they had not determined the economic impact of the problem on potassium seed recovery or how the problem might affect the overall operating characteristics of a fully integrated topping and bottoming cycle system.

---

## Channel Operation Problems

The initial shutdown inspection also disclosed problems with lifting of the platinum caps covering the electrodes imbedded in the MHD channel. The channel is lined with about 2,500 electrode segments, which capture the electric current generated in the MHD topping cycle process. The electrode segments are capped with a protective layer of platinum. About 100 of the caps had lifted during the test run. The contractor replaced some of the caps and placed the MHD channel back into operation. According to DOE, when the channel was inspected again in mid-June 1993, the cap-lifting problem still existed. The impact of the problem will not be fully known

---

until the duration testing is completed. DOE officials believe this problem is related to the process of attaching the caps to the electrodes.

---

### Concerns About the Cost-Effectiveness of Seed Regeneration Process

Although the seed regeneration system developed by TRW under the POC program works, questions remain about the economic viability of the process. According to a DOE official, on-site seed regeneration is essential for large-scale MHD plants. However, recent TRW estimates show that the cost of seed regeneration in an MHD power system using high-sulfur coal would be more than 20 percent of the average sales price of the electricity generated by the system. According to DOE officials, this factor may lower an expected cost advantage for MHD technology in producing electricity. According to TRW, seed regeneration costs could be reduced by using low-sulfur coal. But using low-sulfur coal would take away one of MHD's major advantages—its ability to burn high-sulfur coal and still meet strict air pollution standards.

---

### Uncertainties in Fully Integrating MHD Systems

Under the POC program, the topping and bottoming cycle systems have been tested separately but not together. Therefore, problems could occur when the two systems are fully integrated with each other. University of Tennessee Space Institute officials told us that while they felt that the testing facilities were effective in replicating the operating conditions of an integrated topping and bottoming cycle system, they believe that unanticipated problems are likely to occur in a truly integrated MHD facility. They said the problems of merging the two systems cannot be identified until the systems are actually integrated and operated together. DOE officials told us that integration issues are being studied at the Montana facility with EPRI funds. They also indicated that component integration problems could be experienced with any technology development and would not be unique to MHD.

---

### Uncertainties in Scaling Up MHD Systems

According to University of Tennessee Space Institute officials, new problems are also likely to arise as the size and power output of an MHD system is increased in scale beyond that being tested under the POC program. They said that scale-up problems cannot be fully anticipated from the scale of testing being done under the POC program. To minimize the risk of scaling up an MHD system, the officials believe that MHD plants must be developed and demonstrated in stages; each stage would represent a larger-scale plant.

---

The potential efficiency of an MHD power generation system is greatly affected by the size of the plant. Larger MHD plants would be much more efficient than smaller plants. For example, an 80-megawatt plant using MHD technology would be expected to achieve about 33-percent efficiency, but successfully demonstrated MHD plants could be scaled up to potentially achieve 44-percent or higher efficiencies (for oxygen-enriched systems), according to DOE.

Under DOE's Clean Coal Technology program, a number of projects are demonstrating advanced technologies on a commercial scale that are targeted at achieving 40- to 45-percent efficiencies in coal-fired power plants. These technologies are further along the path to commercialization than MHD and will be competing with MHD for use in the utility industry.

---

### Other Advanced Technologies Are Needed If MHD Efficiencies Are to Exceed Those of Competing Coal Technologies

According to DOE, MHD technology has the highest potential efficiency of any heat engine. DOE and MHD authorities have stated that MHD power generating systems could ultimately achieve 55- to 60-percent efficiencies in 15 to 20 years or more. But they have also acknowledged that certain advanced technologies that have not yet been developed will need to be used with the POC program technology if MHD power generation systems are to achieve these high efficiencies. Three such technologies that have not been addressed under the POC program are high-temperature air heaters, ultrasupercritical steam generators, and electrodes capable of operating at much higher temperatures.

According to an analysis by a PETC support contractor,<sup>3</sup> a 450-megawatt MHD power plant would be expected to achieve about 44-percent efficiency without these other technologies. The analysis indicated that a high-temperature air heater would raise the temperature of the air used for coal combustion in the MHD topping cycle to about 2,800 degrees, which would increase the efficiency of a 450-megawatt MHD plant to about 48 percent. According to the analysis, increasing the temperature of the air to 3,100 degrees, through improvements in the high-temperature air heater, would increase the efficiency to about 56 percent. The analysis indicated that the efficiency level could ultimately increase to about 60 percent by (1) developing and using electrodes in the MHD channel that are capable of withstanding much higher temperatures in the topping cycle and (2) developing and using an advanced steam turbine generator, referred to as an ultrasupercritical steam generator, that can operate in the bottoming

---

<sup>3</sup>W. R. Owens, J. H. Hirschenhofer, and R. E. Weinstein, "Commercialization of Magneto hydrodynamics," Gilbert/Commonwealth, Inc. (Nov. 1992).

cycle at much higher temperatures and pressures than currently available technology. DOE officials said that the POC program did not address these technologies because such potential improvements in the MHD process were beyond the scope of the POC program.

## Management of the POC Program

In planning and implementing the POC program, DOE established several management controls that have helped to focus the development of MHD technology and improve the dissemination of accumulated data. For example, DOE centralized the management of the program and developed a multiyear program plan with objectives and milestones for each of the program's components. DOE also used a committee of program participants and other private sector representatives to assess the compatibility of the various program activities and identify technical issues and data needs. In addition, DOE arranged for an independent panel of experts to assess the progress of the POC program in November 1990. The panel concluded that the program was appropriately focused on the major technical issues and was well-managed.

DOE centralized the management and coordination of its MHD program under PETC in 1984, when the POC program was established. According to a November 1983 report by DOE's Office of Inspector General,<sup>4</sup> the MHD program had previously been managed by DOE headquarters as a group of loosely associated projects with year-to-year objectives only. The associated projects had not been integrated into an overall program with comprehensive objectives. Previous government efforts to develop MHD technology had also been criticized in congressional hearings for "start and stop" policies that had an adverse impact on the effectiveness of federal expenditures.

By contrast, under the POC program all contract specifications were developed by PETC, and the separate components and systems have all been coordinated under DOE's multiyear plan. The plan contains objectives and milestones for implementing the program and demonstrating the proof-of-concept of each of the program components. It also outlines the tasks needed to achieve the objectives. PETC has overseen all program activities and has an on-site technical representative at the Montana facility. A technical representative from DOE's Chicago Operations Office has assisted in overseeing the activities at the Tennessee facility. DOE has essentially followed its POC program plan but has had to extend the

<sup>4</sup>Report on the Magnetohydrodynamics (MHD) Program Administered by the Department of Energy (DOE/IG-0200, Nov. 15, 1983).

---

program by 1 year and cut back on some of the planned testing, as previously discussed.

From June 1988 to June 1992, DOE had a committee of POC program participants and other organizations periodically review the technical activities of the program to help ensure that the individual projects were compatible and consistent with the overall program goal of developing a usable MHD data base. This committee, called the MHD Technology Transfer, Integration and Review Committee, was also responsible for identifying technical issues that could adversely affect adoption of MHD by the private sector. The committee, co-chaired by a PETC program official and an industry representative, consisted of representatives from DOE, POC program contractors, participating universities and national laboratories, several utilities, equipment suppliers, and other potential MHD users or investors. Among other things, the committee participated in periodic meetings with DOE and the MHD community to provide technical information on the results of the POC program, published semiannual reports on the status and progress of major program activities, and advised DOE on technical issues and technology data base "gaps" that must be addressed for compiling MHD system information in a manner that will facilitate technology transfer to the private sector.

The results and progress of the POC program have also been shared with industry and other interested parties through contractors' annual review conferences sponsored by PETC, annual symposia on engineering aspects of MHD sponsored by industry, and biennial international conferences on MHD. DOE distributes the reports from the contractors' review conferences, as well as technical progress reports on the major POC program components, to the MHD community and to other interested parties that request such information. To facilitate general public access to this information, DOE catalogs the conference reports, technical progress reports, and other research reports into an online data base maintained by the National Technical Information Service.

---

## DOE's Future Plans for MHD

When testifying on DOE's fiscal year 1994 budget request for fossil energy programs,<sup>5</sup> the Acting Assistant Secretary for Fossil Energy pointed out that DOE will complete the MHD POC program by September 1993. The official stated that the topping cycle tests at the Montana facility, the bottoming cycle tests at the Tennessee facility, and the seed regeneration

---

<sup>5</sup>Statement by the Acting Assistant Secretary for Fossil Energy, DOE, before the Subcommittee on Interior and Related Agencies, House Committee on Appropriations, Apr. 21, 1993.

---

tests at the TRW plant in Capistrano, California, have shown the technical feasibility of each major subsystem.

In late 1992, a consortium of private companies and organizations that are involved in the POC program and considered to be leaders in the development of MHD in the United States submitted a project proposal to conduct a commercial-scale demonstration of MHD technology under round five of DOE's Clean Coal Technology program. Under this program, DOE funds up to 50 percent of the costs of industry-sponsored projects to demonstrate commercial-scale applications of innovative clean coal technologies, and industry and other nonfederal sources fund the balance. The program is intended to accelerate the commercialization of advanced, more efficient, and environmentally acceptable technologies to help the nation make greater use of its vast coal resources.

The consortium's proposal was comprehensively evaluated, along with 21 other project proposals, but was not one of the 5 projects that were ultimately selected, on May 4, 1993, to participate in this program.<sup>6</sup> According to DOE, the five selected projects received the highest ratings in their respective areas of technology type and hold the greatest promise for the advancement of the efficiency and environmental performance of coal-using technologies among those submitted in response to the solicitation. DOE did not select a project from each type of technology proposed because of funding limitations and because DOE wanted to limit the selection to the highest-rated proposals.

DOE has requested \$4.8 million in its fiscal year 1994 budget request for fossil energy programs to begin the shutdown and wrap-up of the POC program. These funds are to be used primarily for contract liability costs, such as severance costs for contractor personnel, material and equipment cancellations, termination proposals, contract fees and overhead adjustments, facility and equipment lay-up, and property management and disposition. According to DOE, it will take 2 years to complete the shutdown and require additional funding in fiscal year 1995 for site and

---

<sup>6</sup>The MHD proposal had called for a completely integrated, stand-alone MHD/steam combined-cycle plant to be built in Billings, Montana, at a site owned by the Montana Power Company. The plant was to have generated about 80 megawatts of electrical power. The demonstration project was estimated to cost about \$520 million. DOE had been requested to fund about \$220 million of the estimated costs, and the other \$300 million was to have been funded by the private sector and the state of Montana.



environmental restoration costs and contingencies. DOE has estimated that the total shutdown costs could range from \$8 million to \$16 million.<sup>7</sup>

According to DOE, it would cost an additional \$23 million to complete the topping and bottoming cycle tests in fiscal year 1994. DOE officials said that funds have not been requested to complete these tests because of budget constraints. The officials indicated that there should be adequate test data by September 1993 for the private sector to decide whether to pursue the scale-up of MHD technology, but as previously mentioned, the data may not be as statistically reliable as additional test hours would provide.

---

## Views of Agency Officials

We discussed the facts and other information presented in this report with DOE officials in charge of the POC program, including the Director, PETC; the Director of the Advanced Power Generation and Fundamental Research Division at PETC; the Associate Director, Office of Project Management at PETC; and the Director and the MHD Program Manager, Office of Special Technologies, at DOE headquarters. The officials agreed with the factual information presented, and their views have been incorporated in the report where appropriate. As requested, we did not obtain written agency comments on a draft of this report.

---

Our work was performed from October 1992 to June 1993 in accordance with generally accepted government auditing standards. The scope and methodology of our review are described in appendix III.

As arranged with your office, unless you publicly announce its contents earlier, we plan no further distribution of this report until 7 days from the date of this letter. At that time, we will send copies of this report to the Secretary of Energy; appropriate congressional committees and subcommittees; the Director, Office of Management and Budget; and other interested parties. We will also make copies available to others on request.

---

<sup>7</sup>These shutdown cost estimates do not include the costs to verify and document the fiscal year 1993 test results in a format usable by industry. DOE has estimated that to do this would cost about \$400,000 (\$200,000 for topping cycle data, \$150,000 for bottoming cycle data, and \$50,000 for seed regeneration data). According to DOE's Deputy Assistant Secretary for Advanced Research and Special Technologies, this omission was an oversight and the fiscal year 1993 test results will be properly documented for industry's use.

---

Should you need further information, please contact me at (202) 512-3841.  
Major contributors to this report are listed in appendix IV.

Sincerely yours,

A handwritten signature in black ink, appearing to read "Victor S. Rezendes". The signature is fluid and cursive, with the first name being the most prominent.

Victor S. Rezendes  
Director, Energy and Science Issues



---

# Contents

---

Letter	1
Appendix I Schematic of a Magnetohydrodynamics Electric Power Plant	20
Appendix II Summary of Private Sector Contributions for Development of MHD Technology During Fiscal Years 1986 Through 1991	22
Appendix III Scope and Methodology	24
Appendix IV Major Contributors to This Report	26
Figure	4

---

Figure 1: MHD Federal Funding Trend

---

## Abbreviations

DOE	Department of Energy
EPRI	Electric Power Research Institute
GAO	General Accounting Office
MHD	magnetohydrodynamics
PETC	Pittsburgh Energy Technology Center
POC	proof of concept



# Schematic of a Magnetohydrodynamics Electric Power Plant

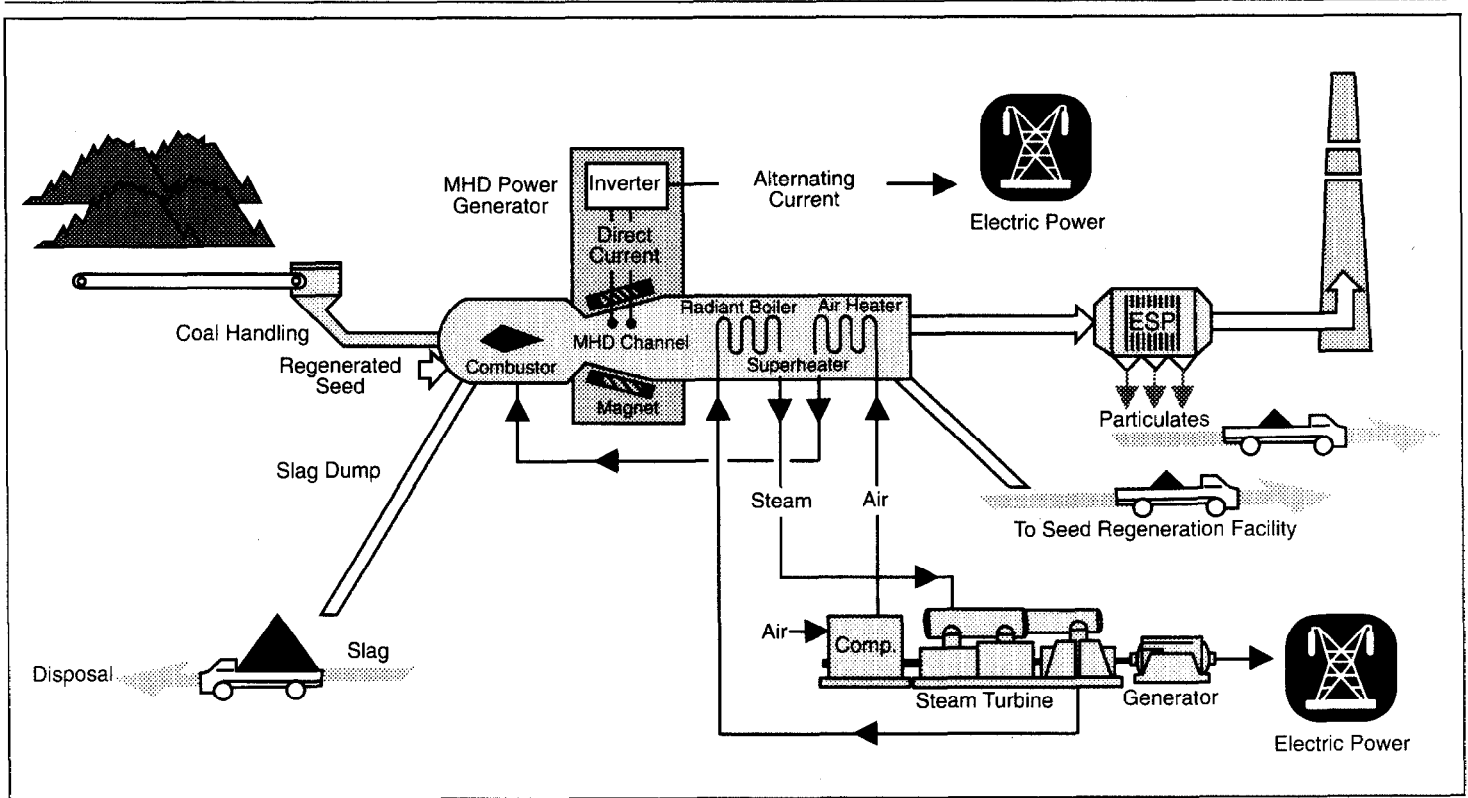

Note: ESP stands for electrostatic precipitator.

Source: Department of Energy.



# Summary of Private Sector Contributions for Development of MHD Technology During Fiscal Years 1986 Through 1991

<b>Fiscal year</b>	<b>Required</b>	<b>Actual</b>	<b>Difference</b>	<b>The Babcock and Wilcox Company</b>
1986	\$ 408,300	\$ 504,662	\$ 96,362	\$21,222
1987	822,200	911,906	89,706	0
1988	1,588,000	1,614,391	1,455,591	0
1989	955,000	1,759,203	804,203	0
1990	2,754,850	2,947,690	192,840	0
1991	1,588,000	2,590,197	1,002,197	0
<b>Total</b>	<b>\$8,116,350</b>	<b>\$10,328,049</b>	<b>\$2,212,199</b>	<b>\$21,222</b>



**Appendix II  
Summary of Private Sector Contributions  
for Development of MHD Technology  
During Fiscal Years 1986 Through 1991**

<b>University of Tennessee Space Institute</b>	<b>Westinghouse Electric Corp.</b>	<b>MSE, Inc.</b>	<b>TRW</b>	<b>MHD Development Corp.</b>	<b>Montana Power Company</b>	<b>EPRI</b>	<b>Textron Defense Systems*</b>
\$148,817	\$11,720	\$ 10,643	\$ 67,000	\$ 0	\$16,670	\$ 228,590	\$ 0
0	0	11,261	529,300	0	0	288,023	83,322
0	0	266,358	791,700	197,506	0	228,590	130,237
0	0	12,180	1,459,000	0	0	288,023	0
0	0	28,667	2,631,000	0	0	288,023	0
0	0	29,174	2,273,000	0	0	288,023	0
<b>\$148,817</b>	<b>\$11,720</b>	<b>\$358,283</b>	<b>\$7,751,000</b>	<b>\$197,506</b>	<b>\$16,670</b>	<b>\$1,609,272</b>	<b>\$213,559</b>

\*Textron Defense Systems was formerly known as Avco.

# Scope and Methodology

---

Our review covered the Department of Energy's (DOE) progress in implementing its magnetohydrodynamics (MHD) proof-of-concept (POC) program. In obtaining information on the POC program's financial history, we reviewed DOE's budget requests, relevant annual appropriations acts, program implementation plans, and other program documents. We also asked DOE officials to provide information on federal and private sector funding for MHD research and development since the 1960s. We documented federal and private sector funding data on an annual basis to the extent that such information was available.

To compare the actual progress of the POC program with its scheduled progress, we reviewed DOE's annual MHD program plans, a special DOE report on revising the program's schedule and funding requirements, other DOE reports and publications, contractors' technical progress reports, and an independent study that assessed the program. We also reviewed scientific articles and conference papers prepared by MHD researchers participating in the POC program. In addition, we interviewed contractors' representatives at the Montana and Tennessee testing facilities; other MHD authorities involved with the program; and DOE officials at the Pittsburgh Energy Technology Center (PETC), Chicago Operations Office, Montana testing facility, and DOE headquarters.

We also reviewed various DOE and private sector reports on the POC program and interviewed DOE and private sector program participants to identify potential problems and areas of concern. In addition, we toured the Montana and Tennessee testing facilities and discussed test results and inspection observations with DOE and contractors' representatives. We also obtained the views of several MHD authorities who were not participating in the program.

In assessing DOE's management of the POC program, we reviewed DOE reports and testimonies, congressional hearing records, POC program documents, and an independent assessment of the program. We also discussed management issues with DOE headquarters and PETC officials, POC program contractors' representatives, and other MHD authorities.

In obtaining information on DOE's future plans for MHD, we reviewed relevant DOE budget documents, testimony, and other records and interviewed DOE headquarters and PETC officials. We also reviewed public information on the proposed MHD demonstration project that was submitted for federal cost-sharing consideration under round five of DOE's Clean Coal Technology program and DOE's public records on the process

---

**Appendix III  
Scope and Methodology**

---

used and the rationale considered by DOE in evaluating and selecting the round-five clean coal projects.

---

# Major Contributors to This Report

---

**Resources,  
Community, and  
Economic  
Development  
Division, Washington,  
D.C.**

Jim Wells, Associate Director  
Gregg A. Fisher, Assistant Director  
Marcus R. Clark, Jr., Assignment Manager

---

**Chicago Regional  
Office**

John R. Richter, Regional Management Representative  
Stewart O. Seman, Evaluator-in-Charge  
David G. Ehrlich, Staff Evaluator

---

### Ordering Information

The first copy of each GAO report and testimony is free. Additional copies are \$2 each. Orders should be sent to the following address, accompanied by a check or money order made out to the Superintendent of Documents, when necessary. Orders for 100 or more copies to be mailed to a single address are discounted 25 percent.

**Orders by mail:**

U.S. General Accounting Office  
P.O. Box 6015  
Gaithersburg, MD 20884-6015

**or visit:**

Room 1000  
700 4th St. NW (corner of 4th and G Sts. NW)  
U.S. General Accounting Office  
Washington, DC

Orders may also be placed by calling (202) 512-6000  
or by using fax number (301) 258-4066.

---

United States  
General Accounting Office  
Washington, D.C. 20548

Official Business  
Penalty for Private Use \$300

First-Class Mail  
Postage & Fees Paid  
GAO  
Permit No. G100

---